

## HHK 12A Hydraulic Impact Hammer

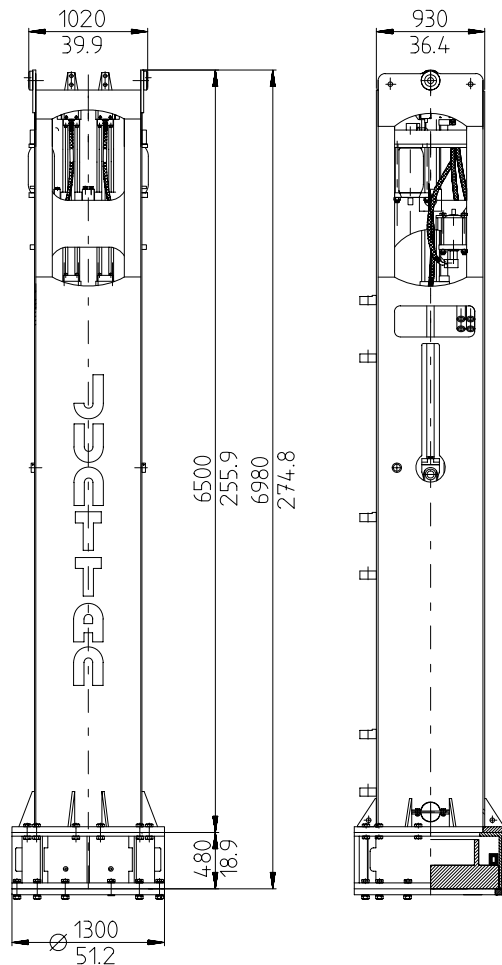

JUNTTAN HHK 12A		
Max. energy	kNm (ft-lbs)	141 (104 200)
Drop height	mm (inch)	50 - 1200 (2 - 47.2)
Blows per minute		40 - 100
Ram weight	kg (lb)	12 000 (26 460)
Total weight including A-type drive cap	kg (lb)	20 200 (44 530)
Oil flow	l/min (gpm)	650 (172)
Operating pressure	bar (PSI)	210 (3 046)
Hoses - pressure line	mm (inch)	2 x38 (1 ½)
- return line		2 x38 (1 ½)
Drive cap types		A for metal tubes B for concrete piles
Drive cap max. inner diameter	mm (inch)	A: O 1030 (40.55) B: □ 670x670 (26.4 x 26.4)
Larger drive cap diameters available on special request		
Suitable power packs		10 CCU - 30 CCU
Optional equipment		
<ul style="list-style-type: none"> <li>• guide claws</li> <li>• energy measurement device</li> </ul>	<ul style="list-style-type: none"> <li>• additional drive caps</li> <li>• pile sleeves</li> <li>• lifting cat</li> </ul>	<ul style="list-style-type: none"> <li>• power packs</li> <li>• additional noise insulation package</li> </ul>

Junttan Oy reserves the right to amend the specification without prior notice. Error and misprints reserved. 3 March 2005 - version M1HHK12A001.