

## HHK 9S Hydraulic Impact Hammer

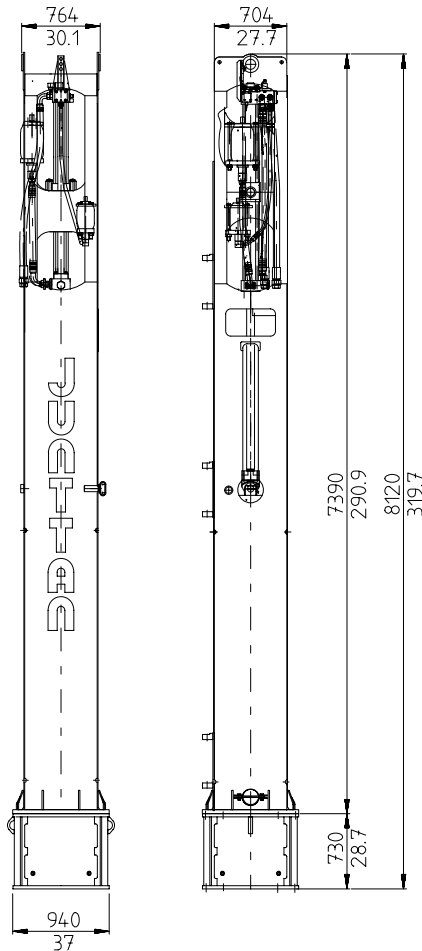

JUNTTAN HHK 9S		
Max. energy	kNm (ft-lbs)	132 (97 700)
Drop height	mm (inch)	50 - 1500 (2 - 59.1)
Blows per minute		30 - 100
Ram weight	kg (lb)	9 000 (19 840)
Total weight including A-type drive cap	kg (lb)	16 000 (35 270)
Oil flow	l/min (gpm)	350 (90)
Operating pressure	bar (PSI)	260 (3 771)
Hoses - pressure line	mm (inch)	38 (1 ½)
- return line		38 (1 ½)
Drive cap types		A for metal tubes B for concrete piles
Drive cap max. inner diameter	mm (inch)	A: Ø 830 (32.7) B: □ 550x550 (21.6x21.6)
Larger drive cap diameters available on special request		
Suitable power packs		5 CCU - 30 CCU
Optional equipment		
<ul style="list-style-type: none"> <li>• guide claws</li> <li>• energy measurement device</li> </ul>	<ul style="list-style-type: none"> <li>• additional drive caps</li> <li>• pile sleeves</li> <li>• lifting cat</li> </ul>	<ul style="list-style-type: none"> <li>• power packs</li> <li>• additional noise insulation package</li> </ul>

Junttan Oy reserves the right to amend the specification without prior notice. Error and misprints reserved. 3 March 2005 - version M1HHK9S001.