

HHU 5S Hydraulic Impact Hammer

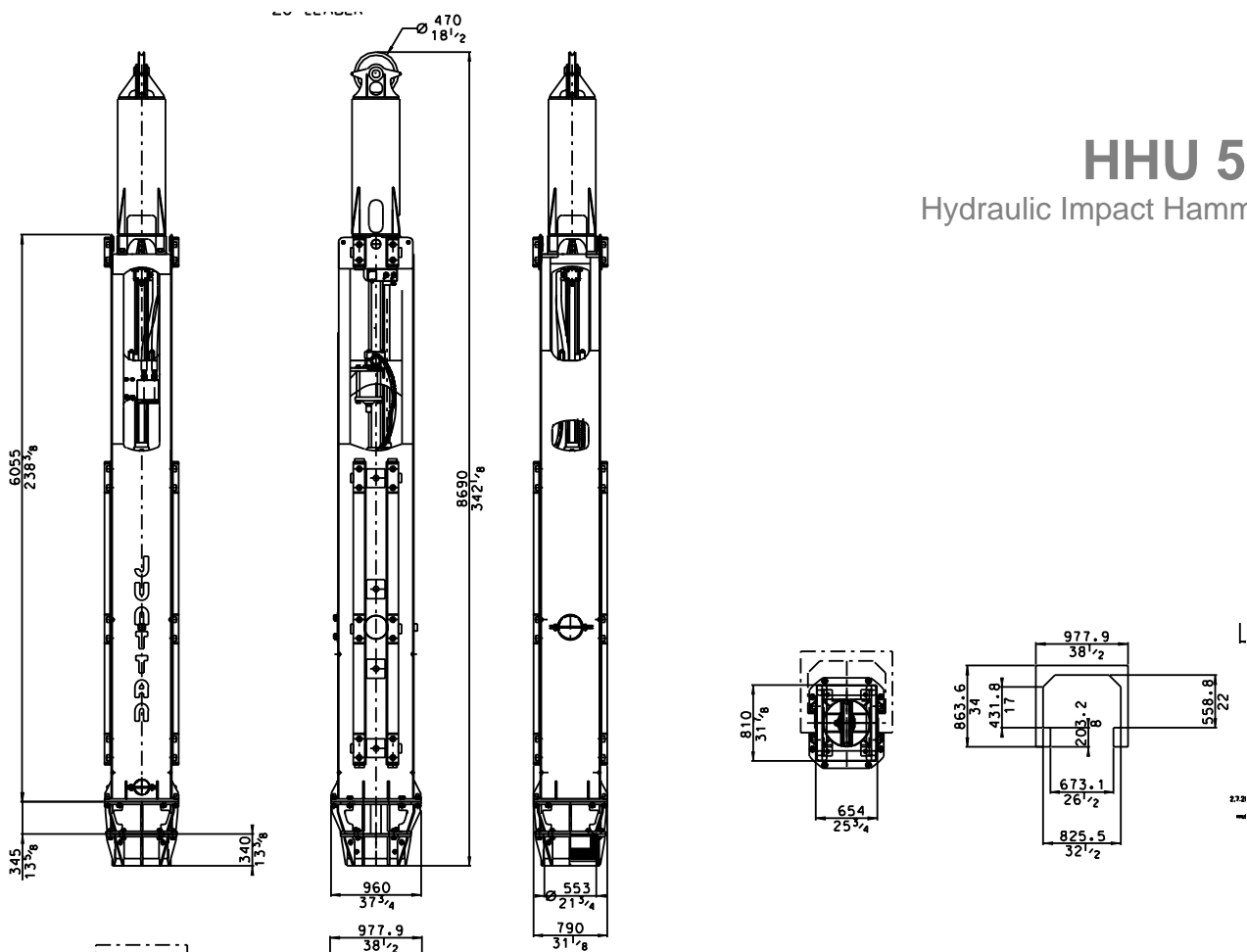

JUNTTAN HHU 5S		
Max. energy	kNm (ft-lbs)	74 (54 679)
Drop height	m (ft)	0.05 - 1.5 (0.16 - 4.9)
Blows per minute		30 -100
Ram weight	kg (US ton)	5 000 (5.5)
Total weight incl. A-type drive cap	kg (US ton)	9 000(9.9)
Oil flow	l/min (gpm)	340 (90)
Operating pressure	bar (PSI)	168 (2450)
Hoses - pressure line	mm (inch)	38 (1 1/2)
- return line		38 (1 1/2)
Drive cap types		A for metal tubes B for concrete piles
Drive cap max. inner diameter	mm (inch)	A: O 830 (32.7) B: □ 450x450 (21.6x21.6)
Larger drive cap diameters available on special request		
Suitable power packs		5 CCU- 30CCU
Optional equipment		
<ul style="list-style-type: none"> guide claws energy measurement device 	<ul style="list-style-type: none"> additional drive caps pile sleeves lifting cat 	<ul style="list-style-type: none"> power packs additional noise insulation package

Junttan Oy reserves the right to amend the specification without prior notice. Error and misprints reserved. 3 March 2005 - version M1HHU5S001.